

# THE INVENTION OF CMOS IMAGE SENSORS: A CAMERA IN EVERY POCKET

Eric R. Fossum  
Thayer School of Engineering, Dartmouth College  
NH, USA  
eric.r.fossum@dartmouth.edu

## ABSTRACT

As of 2020, CMOS image sensors are expected to enable the production of about 200 cameras every second around the world, or over 6 billion per year. In this talk, the story of how we got here is briefly presented, from CCDs, to the invention of the CMOS image sensor at the NASA Jet Propulsion Laboratory in the 1990s, to the present.

Key words: image sensor, CCD, CIS, CMOS, Quanta image sensor, photon-counting, QIS

## INTRODUCTION

For better or worse, cameras have become a ubiquitous part of modern life. Solid-state image sensors, such as the charge-coupled-device (CCD), and in the past 20 years, the CMOS image sensor (CIS), have powered these cameras. In this brief paper, the overall trajectory of the invention, development, commercialization and possible future path of image sensors will be discussed. The reader is referred to the cited papers for a more complete view of the history.

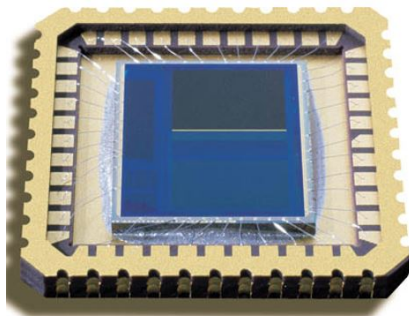


Figure 1. Early CMOS image sensor chip

## UNDERLYING TECHNOLOGY

At the heart of every camera, where the conversion from light to electronic signal takes place, is the image sensor – an integrated circuit (Fig. 1). The optics of the camera focus the light as an image on the surface of the sensor, which also has its own optical structures [1], and absorption of visible-light photons creates electron-hole pairs in the semiconductor. The quantum efficiency (QE) is the ratio of useful photoelectrons to incident photons and often ranges from 50% to 80% (Fig. 2). The photoelectrons are collected by diffusion and drift into an electrostatic “potential well” created by selective semiconductor doping via ion implantation. Photoelectrons are integrated in this storage well during the exposure (Fig. 3). The pinned photodiode structure, invented by

Teranishi, is often used in CCDs and CMOS image sensors [2,3]. At the end of the exposure integration period, the charge-domain signal is then converted to voltage by transferring the charge to a sense capacitance. The change in the charge on this sense node causes a change in voltage, thus converting the signal from charge domain to voltage domain (Fig. 4).

The change in voltage may be amplified or buffered by conventional electronics, but most often first by the gate of a source-follower MOSFET. The relationship between the change in output voltage and the number of photoelectrons is called the conversion gain (CG) with units of volts/electron. Typical CGs today are in the 30-75uV/e- range.

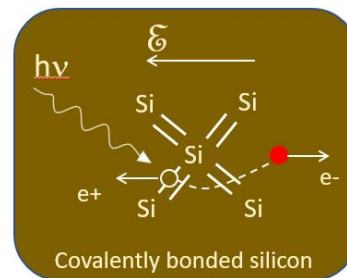


Figure 2. A photon with energy  $h\nu$  breaks a silicon bond and frees both an electron ( $e^-$ ) and a hole ( $e^+$ ).

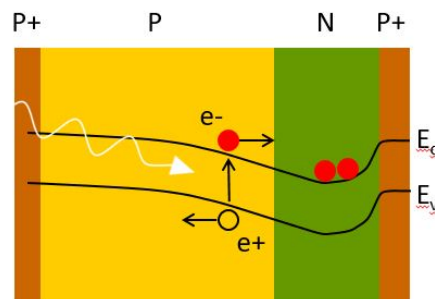
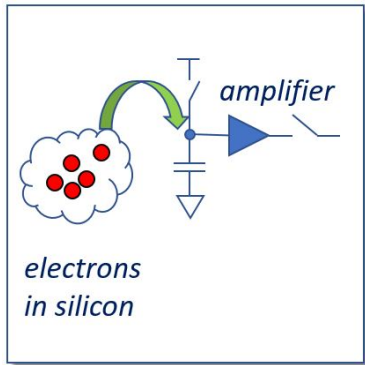


Figure 3. Photoelectrons are collected in an electrostatic storage well (N-region) created by selectively doping the silicon.

Photon arrival rates are well-described by Poisson statistics, with a variance equal to the mean. Thus, repeated measurements of the same average photon flux will yield different results each time, and the standard deviation is referred to as photon shot noise. The signal-to-noise ratio (SNR) thus varies as the square root of the signal level,

leading to low SNR at low signal levels. Thus, in low light, the signal often appears relatively more noisy (or “grainy”). The SNR can be improved by increasing the exposure time to increase the signal, and is limited according to the maximum number of photoelectrons that can be stored in the storage well (so-called “full well capacity” or FWC). An FWC of several thousand electrons is typical, leading to a maximum SNR of perhaps 50-70 or so.



**Figure 4.** During readout of a CCD or CMOS image sensor, the signal charge is transferred onto a sense capacitance whose change in voltage is measured by an amplifier. For CDS, the amplifier voltage is sampled twice, once just before charge transfer, and once right after charge transfer, and then taking the difference.

Noise is also introduced by the readout process due to various noise sources in the readout circuit transistors and reset noise on capacitors. The use of correlated double sampling (CDS) is one way to reduce reset noise and  $1/f$  transistor noise. Correlated multiple sampling (CMS) may also be used. For larger signals, photon shot noise is the dominant noise. For low-light levels, the readout noise becomes critical in determining SNR. The readout noise is often referred to the equivalent number of input photoelectrons. For example, 150 $\mu$ V rms of read noise with a CG of 50 $\mu$ V/e<sup>-</sup> would be input-referred as 3e<sup>-</sup> rms. These days the read noise of image sensors is typically in the 2-5e<sup>-</sup> rms range and is often dominated by  $1/f$  noise from the first source-follower transistor.

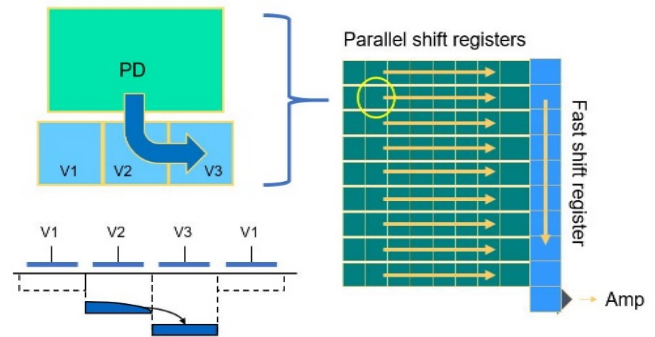
### EARLY SOLID-STATE IMAGE SENSORS

In the 1960s, several groups pioneered building solid-state image sensors. Weckler at Reticon realized that one could integrate photoelectrons on the built-in capacitance of a floating PN photodiode. This charge could then be readout by connecting the PN junction via a MOSFET switch to a readout circuit. This is now called a passive MOS image sensor. Noble at Plessey worked contemporaneously and built on Weckler’s idea by using a source-follower as a readout amplifier. Adding a switch to reset the photodiode and a switch to connect the source-follower to some additional readout sequencing circuits, Noble’s image sensor was the first three-transistor (3T) active pixel sensor. Noble also suggested a buried photodiode, a predecessor of the pinned photodiodes used today [4]. Unfortunately, these early approaches yielded neither good nor stable image

quality due to limitations of the circuit configuration and semiconductor technology of the mid 1960’s. Images suffered from large temporal noise and fixed pattern noise. The circuit was susceptible to drifts in operating voltage and manufacturing yield. Reticon and Hitachi later continued to explore these passive pixel and 3T active pixel approaches but none achieved viable commercial success due, in part, to the above but also due to the imminent invention and rapid development of CCDs.

### CHARGE-COUPLED DEVICE (CCD)

In 1969, the charge-coupled device concept was invented at Bell Labs as a solid-state equivalent to magnetic bubble memory. The CCD was based on the MOS gate structure using a series of adjacent gates. By pulsing each gate in sequence, minority carriers in the semiconductor (e.g., electrons) can be dragged along in the semiconductor due to electrostatic attraction. The electron signal charge can either be electrically injected or created by light. In the former, the CCD acts like a delay line, and in the latter, the charge (or voltage) that is read out is indicative of the spatial distribution of light. When the CCD is configured as a 2D array of MOS gates, an image can be focused on the device, and the charge from that light pattern read out as a digital image (Fig. 5).



**Figure 5.** Illustration of a CCD interline transfer (ILT) pixel, top view (top left), charge-transfer shift register (bottom left), and a CCD ILT array (right).

The CCD was immune from many of the manufacturing issues that plagued the early passive and active pixel sensors, and efforts in the US, Europe, and especially Japan rapidly developed the CCD into a workhorse image sensor [5]. The CCD image sensor became the basis for consumer camcorders from Japanese manufacturers and later broadcast TV cameras, and by the 1990’s, digital still cameras.

Due to the CCD’s later widespread adoption by astronomers in telescopes, the 2009 Noble Prize in Physics was awarded to Boyle and Smith of Bell Labs “for the invention of an imaging semiconductor circuit – the CCD sensor.” Some controversy erupted [6] over the choice of Smith and Boyle, not because of their invention of the CCD, but because of the prize’s citation. In fact, the patent for the first CCD image sensor lists only Michael Tompsett of Bell Labs [7].

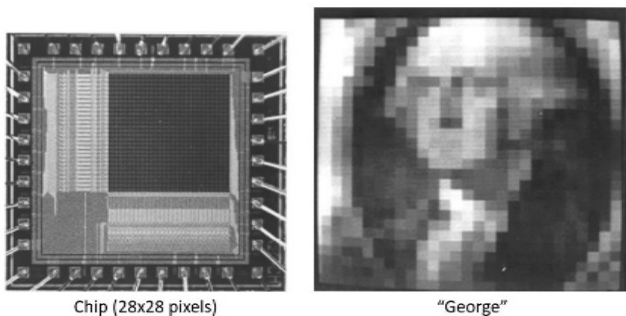
Despite their success, CCD image sensors had many drawbacks due to the thousands of charge transfer steps

required to readout each pixel in the image. The charge transfer requires considerable energy and also a perfect CCD device with transfer efficiency of at least 99.999%. Whenever the pixel count in the image sensor is increased, even more energy is required for readout. The intrinsic performance of the CCD also has to improve since more transfer steps are required and the transfer has to get faster for the same frame rate. CCDs were thus hard to scale to larger sizes. The cost of CCDs was fairly high because the manufacturing process to make a CCD was a very different recipe from that used by mainstream CMOS electronics (e.g. for computers and memory), and essentially every generation of CCD had to have a new and improved process whose development cost was amortized across the sale of those CCDs.

### INVENTION OF CMOS IMAGE SENSORS

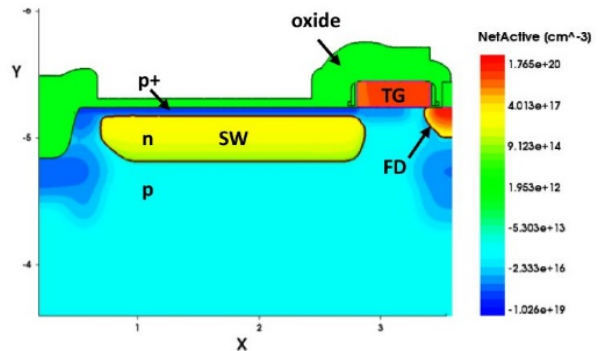
NASA had an additional problem with CCDs it was using in interplanetary spacecraft. Those CCD cameras were exposed to radiation in space that caused microscopic defects in the image sensor chip. The defects resulted in a continuous degradation in performance – both in charge transfer efficiency and dark current (like junction leakage current). Also, the power dissipation of CCD cameras was high - a problem when operating from a battery (CCD camcorder batteries were large, for example, and were depleted after perhaps 30 minutes of use) or a solar panel power supply or a radioisotope thermoelectric generator (RTG) aboard a spacecraft. And, the electronics required to provide timing and clocking signals to drive the CCD, and to process the output signals including analog-to-digital conversion (ADC), were bulky and also power-hungry.

In 1992, the author, working at the NASA Jet Propulsion Laboratory at Caltech, came up with a new approach for image sensors that would use an active pixel sensor with intra-pixel charge transfer and use a mainstream CMOS microelectronics recipe as the baseline [8] (see Fig. 6). By using CMOS, one could not only capture the image, but one could also put all the timing and control circuits and all the signal processing circuits, including ADC, on the same chip. This camera-on-a-chip would allow miniaturization of the spacecraft camera, and reduce power consumption significantly (100x) as well as avoid many of the degradation issues associated with exposure to radiation in space.

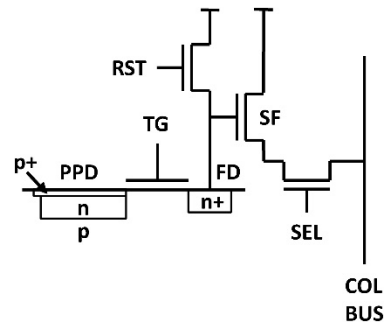


**Figure 6.** First CMOS image sensor chip and acquired 28x28 pixel image of a one-dollar bill from 1993 at JPL.

Each pixel is composed of a tiny CCD with its own readout and selection electronics (see Fig. 7 and Fig. 8). Using intra-pixel charge transfer allows the use of noise reduction techniques like CDS, thus enabling imaging performance comparable to CCDs. By using CMOS as the baseline, the integration of additional signal processing to further improve performance of the active pixel sensor was also possible. A high-quality camera-on-a-chip became feasible [4,9].



**Figure 7.** TCAD simulation of a pinned photodiode (PPD) charge storage region and transfer gate (TG) and sense node (FD) (from Fossum and Hondongwa [10]).

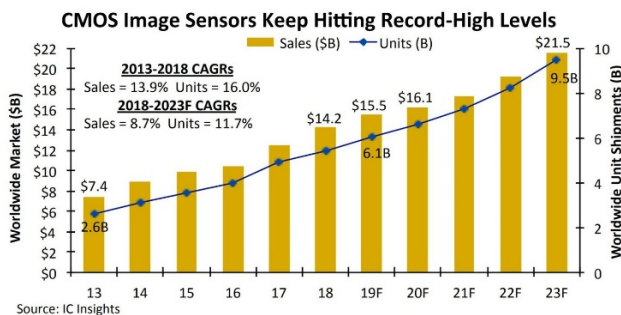


**Figure 8.** Circuit schematic of CMOS image sensor pixel including reset gate (RST), source-follower (SF), and row select switch (SEL).

The early sensors made in 1993-1995 showed great promise and it became clear that the technology was not only useful for space but also for consumers on planet Earth. However, the deeply entrenched CCD industry was very slow to recognize the advantages of the CMOS active pixel sensor camera-on-a-chip. US industry was similarly reluctant to engage with the new technology despite many attempts to evangelize and transfer the technology (with some notable exceptions). In 1995, the author and several members of the team at JPL co-founded a spinoff company, Photobit, to commercialize the technology. Photobit grew to about 135 people before being acquired by Micron in 2001 and produced sensors for web cams, dental x-rays, swallowable pill cameras, high speed machine vision systems, automotive rain wiper and high beam control, drowsy driver warning, star trackers and other applications. By 2001, the “killer-app” of cellphone cameras was very visible on the horizon and Micron became a world leader in this technology [11].

Around the same time, some other large companies such as Sony and Samsung started to make large capital investments and seriously develop CMOS image sensors. Today, these two vertically integrated companies dominate the image sensor market place. Foundries like TSMC and Tower-Jazz also playing a major role for fabless companies. Micron later spun-off the image sensor business as Aptina, and later Aptina was acquired by ON-Semi (which grew out of Motorola).

In 2020, it is estimated that over 6.5 billion image sensors (or the same number of cameras) will be shipped worldwide corresponding to a semiconductor component revenue of \$16.1B [13] as shown in Fig 9. While nearly all of these CMOS image sensors still utilize active pixels with intra-pixel charge transfer, many improvements have been made since the 1992 invention. The use of 3-D stacked structures and back-side illumination (BSI) with deep-trench isolation (DTI) has resulted in significantly improved performance and capability. Shared readout results in pixel pitch reduction, as well as a plummeting cost per pixel [12]. Older CCD “VGA” sensors with 0.3megapixels once cost in the neighborhood of US\$100 in the mid 1990’s. Today, a VGA CMOS image sensor might cost more than 200x less or US\$0.50.



**Figure 9.** CMOS image sensor sales growth according to IC Insights.

CMOS image sensors today are ubiquitous and several image sensors are typically found in every smart phones (e.g. front selfie camera and one or more rear facing cameras) which in turn enabled industry giants like Facebook, Instagram and YouTube. They are also used in nearly every other camera application from automobiles, to swallowable pill cameras to smart doorbells to police body-cams. NASA’s Mars 2020 Rover will have about 20 CMOS image sensor-based cameras on board. While CCD units volume was always small compared to today’s CMOS image sensor units volume, CCD manufacturing has mostly come to an end for most applications.

In 2017, the importance of digital image sensors in everyday life was recognized through the awarding of the Queen Elizabeth Prize for Engineering to Smith & Tompsett (CCD image sensors), Teranishi (pinned photodiode), and Fossum (CMOS image sensor) (Fig. 10).



**Figure 10.** 2017 Queen Elizabeth Prize for Engineering presentation at Buckingham Palace. (L-R, HRH Prince Charles, Fossum, Tompsett, Teranishi)

### QUANTA IMAGE SENSOR

In 2005, a different approach for image sensors was proposed [14]. In this proposed device, single photons would be detected and counted by a large number of specialized yet tiny pixels (called jots) operating at high frame rate. Detection would be essentially binary, either 0 for no photon, or 1 for a photon. Frames of binary data could be used to recreate a gray-scale image, and image in the dimmest possible light. First called a digital film sensor, the name was later changed to Quanta Image Sensor (QIS) [15].

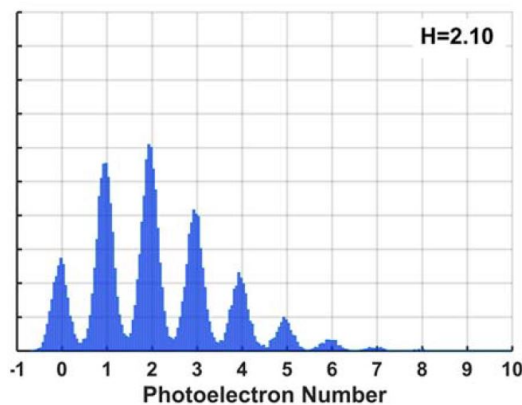
Other groups began to demonstrate the QIS concept and prove the imaging characteristics model using single photon avalanche detector (SPAD) arrays. SPAD devices have been in development for about 24 years and just recently a 1Mpixel SPAD array was reported for the first time with a 9.4um pixel pitch [16]. However, since the SPAD relies on avalanche multiplication for signal gain, it requires high internal electric fields and relatively large spacing between pixels to ensure isolation, and they also typically have high dark count rates (dark current). Despite these issues, SPADs have been proven very useful for fast photon arrival timing applications such as 3-D imaging.

In 2012, work on realizing a CMOS QIS began at the Thayer School of Engineering at Dartmouth. Instead of using avalanche gain to detect single photoelectrons, the gain comes from using a very small sense node capacitance yielding CG in the range of 500uV/e-. Using intrapixel charge transfer, a single electron transferred to that capacitance can produce a signal that is well above the noise floor (e.g. 0.2e- rms noise floor) and thus give a low error rate for detection of single photoelectrons. The detection process is slower than for SPADs, but sub-microsecond timing is achievable. Further, avoiding the high electric fields of SPADs enables smaller pixels or jots, improved manufacturability, and thus lower cost per pixel and smaller optics. Power dissipation is also considerably smaller. In late 2017, Dartmouth reported a 1Mpixel QIS device implemented in a nearly standard CMOS BSI stacked process

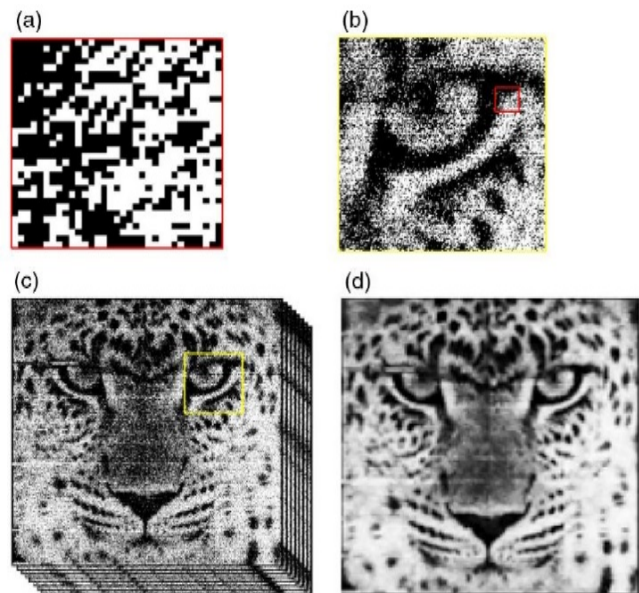
with 1.1 $\mu$ m pixel pitch, operating at 1000fps and dissipating about 20mW total power [17] (see Fig. 10, 11 and 12). The 1Mpixel QIS was demonstrated more than two years earlier than the 1Mpixel SPAD array and with much less development time and with much smaller pixels. About 73 CMOS QIS pixels can fit into the area of one SPAD pixel. This is the strength of working in nearly standard CMOS image sensor processes. The applications of QIS are currently being explored but include low-light imaging for security, defense and science.



**Figure 11.** QIS test chip containing 20 different 1Mpixel arrays designed by Dartmouth and fabricated by TSMC in a 65nm stacked BSI CIS process.



**Figure 12.** Photon-counting histogram (# occurrences vs. normalized readout voltage) showing clear quantization of photoelectrons. The peak heights correspond to the Poisson distribution for an average photoelectron arrival rate of 2.1e-/sample.



**Figure 13.** Data taken from a 1Mpixel array on the QIS test chip. (a) close up of binary image data in one frame, (b) zoomed out version of (a), (c) further zoomed out and illustrating multiple binary frames that are combined to achieve the gray scale image in (d).

## CONCLUSION

CMOS image sensors continue to be used in an ever increasing variety of applications. Some of these applications are useful in every day life, some are for fun (photography), some are for safety, and some continue to test the age-old balance between security and privacy. After 27 years, the future still looks bright for CMOS image sensors.

## ACKNOWLEDGMENTS

The author gratefully acknowledges the manifold contributions of his former and current students, colleagues at JPL, Photobit and Gigajot, and the support of NASA and DoD contracts and SBIR programs and corporate sponsors such as Gentex, Basler, Schick, Given Imaging and Rambus, over many years. CMOS image sensors are only ubiquitous today because of the important contributions of thousands of engineers around the world, as well as the work done by many early pioneers in solid-state image sensors.

## REFERENCES

- [1] N. Teranishi, H. Watanabe, T. Ueda and N. Sengoku, "Evolution of optical structure in image sensors," 2012 International Electron Devices Meeting, San Francisco, CA, 2012, pp. 24.1.1-24.1.4. <https://doi.org/10.1109/IEDM.2012.6479092>
- [2] N. Teranishi, A. Kohono, Y. Ishihara, E. Oda and K. Arai, "No image lag photodiode structure in the interline CCD image sensor," 1982 International Electron Devices Meeting, San Francisco, CA, USA, 1982, pp. 324-327. <https://doi.org/10.1109/IEDM.1982.190285>
- [3] E. R. Fossum and D. B. Hondongwa, "A Review of the Pinned Photodiode for CCD and CMOS Image Sensors," in

IEEE Journal of the Electron Devices Society, vol. 2, no. 3,  
pp. 33-43, May 2014.  
<https://doi.org/10.1109/JEDS.2014.2306412>

[4] E. R. Fossum, "CMOS image sensors: electronic camera-on-a-chip," in IEEE Transactions on Electron Devices, vol. 44, no. 10, pp. 1689-1698, Oct. 1997.  
<https://doi.org/10.1109/16.628824>

[5] A.J.P. Theuwissen, *Solid-State Imaging with Charge-Coupled Devices*, Kluwer Academic Publishers, 1995. ISBN 0-792-33456-6.

[6]<https://spectrum.ieee.org/podcast/semiconductors/devices/who-deserves-credit-for-the-nobelprizewinning-ccd>

[7] US Patent No. 4,085,456 issued 1978.

[8] US Patent No. 5,471,515 issued 1995.

[9] Eric R. Fossum "Active pixel sensors: are CCDs dinosaurs?", Proc. SPIE 1900, Charge-Coupled Devices and Solid State Optical Sensors III, 12 July 1993;  
<https://doi.org/10.1117/12.148585>

[10] E. R. Fossum and D. B. Hondongwa, "A Review of the Pinned Photodiode for CCD and CMOS Image Sensors," in IEEE Journal of the Electron Devices Society, vol. 2, no. 3, pp. 33-43, May 2014.  
<https://doi.org/10.1109/JEDS.2014.2306412>

[11] E.R. Fossum, "Camera-On-A-Chip: Technology Transfer from Saturn to Your Cell Phone," Technology & Innovation, Volume 15, Number 3, 2013, pp. 197-209(13).  
<https://doi.org/10.3727/194982413X13790020921744>

[12] R. Fontaine, "The State-of-the-Art of Smartphone Imagers," in Proc. 2019 Int. Image Sensor Workshop, Snowbird Utah, USA June 2019. [www.imagesensors.org](http://www.imagesensors.org)

[13] <http://www.icinsights.com/news/bulletins/CMOS-Image-Sensors-Stay-On-Stairway-To-Record-Revenues/>

[14] Fossum, E.R. What to do with sub-diffraction-limit (SDL) pixels?—A proposal for a gigapixel digital film sensor (DFS). In Proceedings of the 2005 IEEE Workshop on Charge-Coupled Devices and Advanced Image Sensors, Karuizawa, Japan, 9–11 June 2005. [www.imagesensors.org](http://www.imagesensors.org)

[15] Fossum, E.R.; Ma, J.; Masoodian, S.; Anzagira, L.; Zizza, R. The Quanta Image Sensor: Every Photon Counts. Sensors 2016, 16, 1260. <https://doi.org/10.3390/s16081260>

[16] Morimoto et al, <https://arxiv.org/abs/1912.12910>

[17] J. Ma, S. Masoodian, D. A. Starkey, and E. R. Fossum, "Photon-number-resolving megapixel image sensor at room temperature without avalanche gain," Optica 4, 1474-1481 2017. <https://doi.org/10.1364/OPTICA.4.001474>